

EASTMAN

THE EASTMAN®
CHICKADEE II®
Model CHICK-B

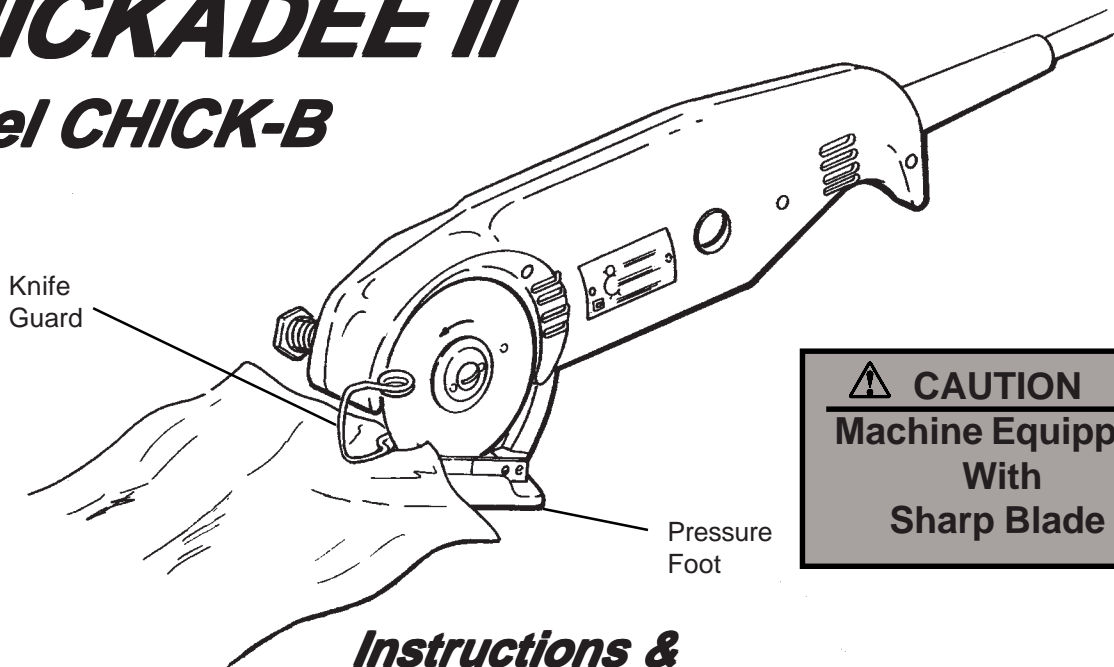

**Instructions &
Illustrated Parts List**

Your new Chickadee II is designed to replace hand held shears for increased performance and capacity with a minimum of maintenance and service. Equipped with either a round blade for general use or hexagonal blade for sheer or difficult to cut cloth. The Chickadee features a totally enclosed sharpener for fast and safe sharpening.

CAUTION

Read instructions carefully before starting motor. Be sure that voltage and current are the same as stamped on nameplate.

TO OPERATE MACHINE

Raise the knife guard up just enough to allow the fabric in over the pressure foot and make contact with the blade. Squeeze the grip activated ON/OFF switch on the bottom of motor housing. If cutter does not perform properly check line output and be sure the unit is plugged in properly, making full contact. Do not attempt to start this unit while knife is in material to be cut.

TO SHARPEN KNIFE

Take the machine out of material to be cut. To obtain a fine, keen edge on the blade, while machine is running press lightly on sharpener button (63C3-22) with a constant pressure. Hold for 10 seconds, then release.

WARNING

Before performing any of the following procedures, make sure the power cord has been disconnected from power source.

LUBRICATION

Follow this procedure yearly for intermittent use, or every six months for continuous use. Remove knife. Remove retainer plate (79C12-276) (2 screws) with gear intact. Then remove screw (20C13-99), emery wheel (541C1-24) and wipe away any grit deposits. Apply a light coat of Eastman Lubriko Grease (242C2) to parts and re-assemble. Then add small quantity of Eastman Lubriko Grease to gears and shaft. Saturate wick (191C1-37) with Eastman's specially compounded oil (242C1) when changing blade.

ADJUSTMENT OF SHEAR PLATE

Shear plate (726C1-17) should contact knife at sharpened edge only. Clearance of back of shear plate is .010" (.25mm) and can be checked with feeler gage.

Eastmanmachine
COMPANY

Illustrated Parts List

Item numbers are for reference only.
Please Specify PART NUMBER when
ordering replacement parts.

ITEM	PART NO.	DESCRIPTION	QTY.
1	523C2-48	Cord Assembly (220V)	1
2	523C2-47	Cord Assembly (110V)	1
3	1C13-26	Cord Sleeve	1
4	300C8-1	Screw, Round Head 4-40 x 3/8	2
5	50C7-26	Cord Clamp	1
6	580C1-103	Switch On/Off	1
7	830C1-11	Circuit Board w/Switch (110V)	1
8	830C1-10	Circuit Board w/Switch (220V)	1
9	829C1-4	Magnet Assembly	1
10	57C1-63	Switch Lever	1
11	122C1-28	Motor Housing, Left	1
12	301C8-1	Screw, Fil. Head 4-40 x 1/2	1
13	301C8-5	Screw, Fil. Head 4-40x1 1/2	1
14	708C1-15	Brush w/Spring	2
15	86C7-42	Brush Cap	2
16	4C1-149	Nut, Hex	1
17	300C12-3	Screw, Round Head 8-32 x 3/8	1
18	12C15-124	Washer, Blade Retainer	1
19	53C11-112	Knife Cover Flange	1
20	80C1-147	Round Knife, 2 1/4"	1
21	80C1-149	Hex Knife, 2 1/4"	1
22	301C3-1	Screw, Fil. Head 2-56 x 1/2	2
23	83C4-25	Knife Flange	1
24	20C13-99	Screw, Pan Head	1
25	541C1-24	Emery Wheel	1
26	301C8-4	Screw, Fil. Head 4-40x3/4	1

ITEM	PART NO.	DESCRIPTION	QTY.
27	79C12-276	Gear Retaining Plate	1
28	302C8-2	Screw, Flat Head 4-40 x3/4	2
29	726C1-17	Shear Plate w/Carbide	1
30	305C8-4	Screw, Binding Head 4-40 x 1/8	1
31	68C3-6	Pressure Foot	1
32	301C8-6	Screw, Fil. Head 4-40x3/16	1
33	309C8-3	Setscrew, 4-40 x 1/8	1
34	25C4-169	Knife Guard	1
35	34C8-12	Spring	1
36	301C15-6	Screw, Fil. Head 10-32 x 1	1
37	17C15-133	Armature Pin	1
38	87C7-44	Worm Gear	1
39	90C6-48	Front Bearing	1
40	10C1-45	Fan	1
41	190C1-2	Armature (110V)	1
42	190C1-3	Armature (220V)	1
43	542C1-102	Armature Assembly (110V)	1
44	542C1-103	Armature Assembly (220V)	1
45	18C6-72	Back "O" Ring Half	2
46	18C6-71	Front "O" Ring Half	2
47	191C1-37	Wicking Felt	1
48	87C7-43	Knife Gear	1
49	122C1-27	Motor Housing, Right	1
50	21C6-3	Sharpener Bushing	1
51	34C10-165	Sharpener Spring	1
52	63C3-22	Sharpener Button	1
53	17C15-136	Pin, Label	4
54	79C2-77	Nameplate	2
55	4C2-106	Nut, Hex	1

From the library of: Diamond Needle Corp

To order replacement parts call Customer Service at (716) 856-2200. Please specify model and serial number of machine along with part number, description and quantity of parts in order.

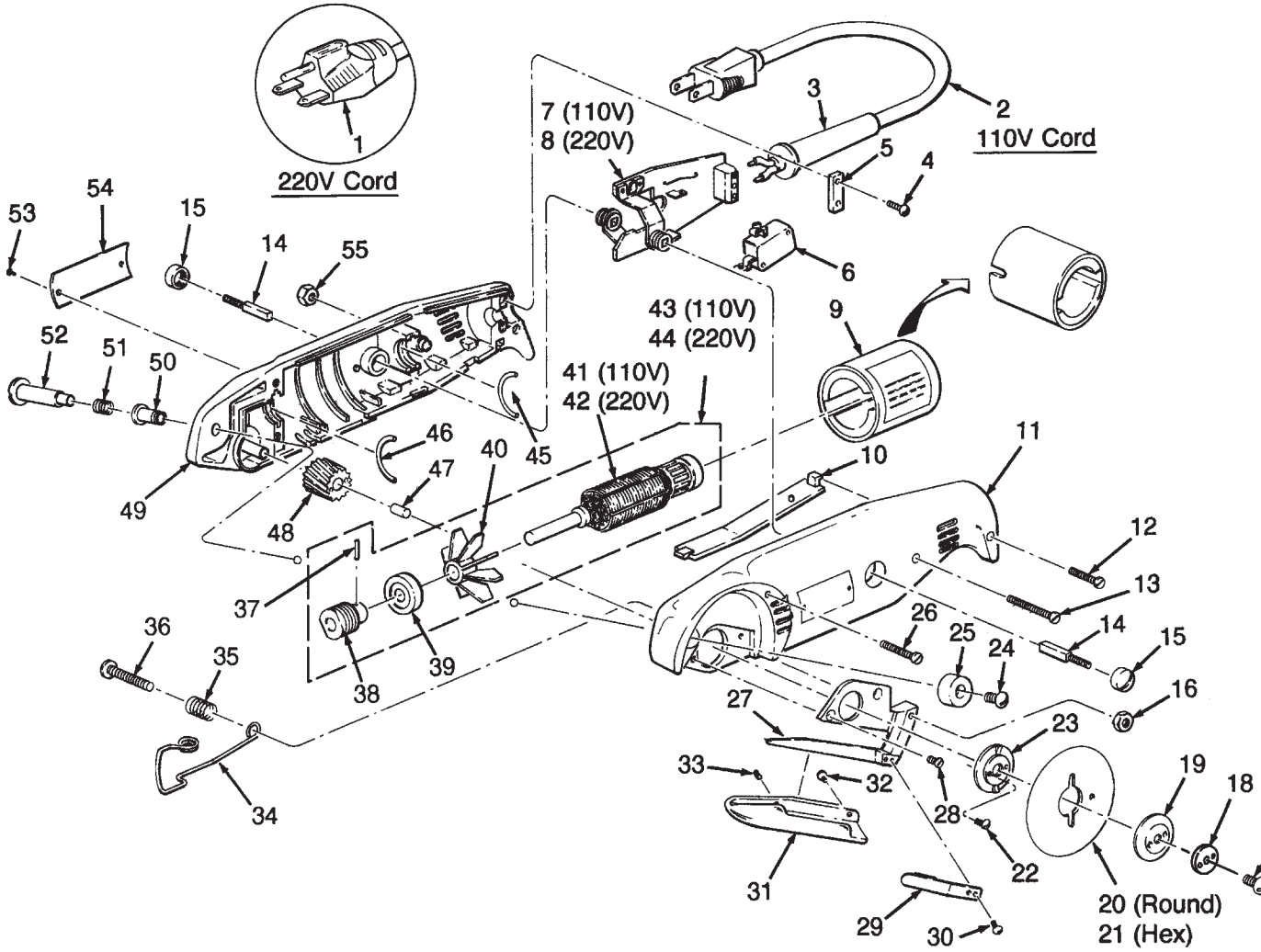

From the library of: Diamond Needle Corp

Optional Base

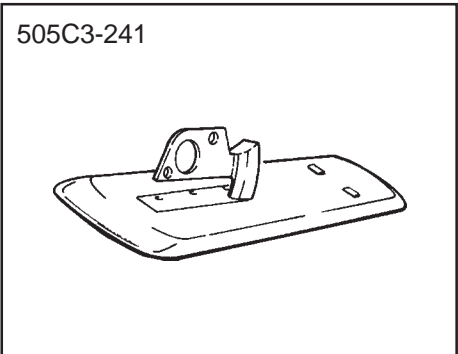

Baseplate:
A small baseplate with needle rollers for a free standing rotary shear. Provides the greatest degree of accuracy from top to bottom ply.

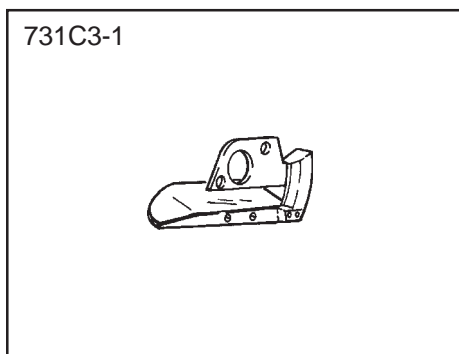

Broad Stabilizer:
For those applications where slightly more stability is necessary, useful for eliminating distortion between plies.

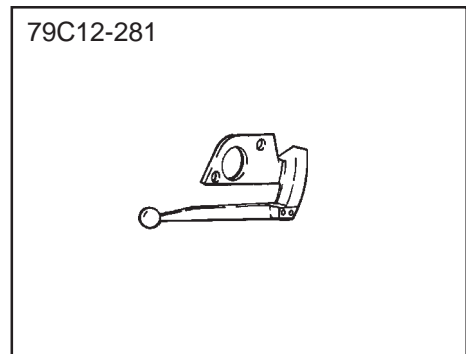

Ball Tip:
Best when slitting tubular knits or other loosely woven materials.



⚠ CAUTION
Machine Equipped
With
Sharp Blade

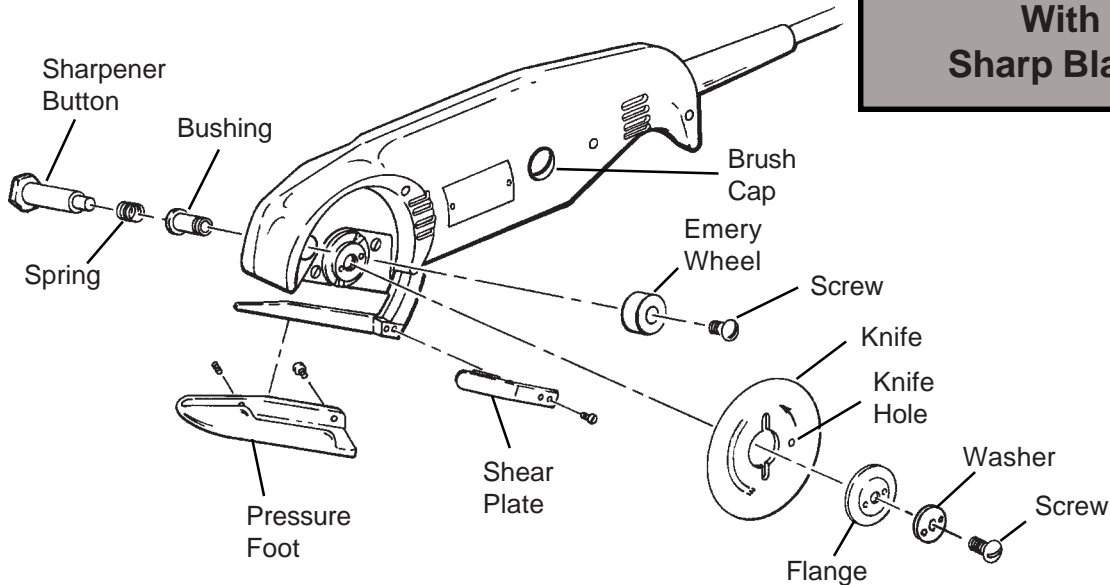

REPLACE MOTOR BRUSHES

Remove black brush caps (86C7-42) from sides of housing with a large bladed screwdriver. Gently pull on springs to remove brushes. If brushes are stuck, tap machine gently on padded surface to loosen brushes.

Replace brushes (708C1-15) if worn to less than 5/32" (4.2mm) or if spring is less than 11/32" (9.0mm). Replace brush caps and tighten gently.

KNIFE REPLACEMENT

Disconnect Chickadee power cord from wall outlet (electric power source). Loosen two screws at pressure foot (68C3-6) and swing foot down out of way. Lay Chickadee on its side with knife facing up. Insert a pin or allen wrench into knife hole.

With large screwdriver in center screw (300C12-3), turn screwdriver counterclockwise until pin locks against housing. Remove screw, washer and flange. CAREFULLY lift out WORN SHARP KNIFE and DISCARD WITH CARE. Lubricate wick with a few drops of Eastman oil. Install new Eastman knife with Eastman facing outward. Slip knife under shear plate and position knife center over two screw heads. Reverse above procedure to secure new knife.

EMERY WHEEL REPLACEMENT

Disconnect Chickadee power cord from wall outlet and remove knife. With Chickadee on its side (knife facing up), hold sharpener button (63C3-22) with suitable wrench. Remove screw (20C13-99) and lift off emery wheel. Install new Eastman emery wheel and reverse above procedure.

Limited Warranty. Eastman warrants to the buyer that the Chickadee II shall be free from defects in materials or workmanship for a period of 90 days commencing on the date of invoice. Any goods or parts claimed by the buyer to be defective must be returned to Eastman, freight charges prepaid, within the 90-day warranty period. If Eastman determines that the goods or parts are defective in materials or workmanship, Eastman's sole obligation under this warranty shall be, at Eastman's sole option, to repair or replace the defective goods or parts or to provide to the buyer a credit equal to the portion of the purchase price allocable to the defective goods or parts. This warranty shall not apply if defects are caused by product misuse or neglect, if the machine has been altered or modified by the buyer, or if other than genuine Eastman belts, emery wheels, knives or parts are used in the machine. THIS WARRANTY IS THE ONLY WARRANTY APPLICABLE TO THIS PURCHASE. SELLER DISCLAIMS ALL OTHER WARRANTIES, EXPRESS OR IMPLIED, INCLUDING, BUT NOT LIMITED TO, THE IMPLIED WARRANTIES OF MERCHANTABILITY AND FITNESS FOR A PARTICULAR PURPOSE.

Limitation of Liability. Eastman's liability to the buyer, and the buyer's remedies from Eastman, whether in contract, negligence, tort, under any warranty or otherwise, shall be limited to the remedies provided in the foregoing Limited Warranty. In no event shall Eastman have any responsibility or liability to the buyer for (a) any special, indirect, incidental, or consequential damages, including, but not limited to, loss of use, revenue, or profit, even if Eastman has been advised of the possibility of such damages, or (b) any claim against the buyer by any third party. The price stated for the product sold is a consideration for limiting Eastman's liability.

Eastman
machine
COMPANY

779 Washington St., Buffalo, N.Y. 14203-1396 U.S.A. • (716)856-2200 • Fax (716)856-1140 or (716)856-2068
 Manufacturers of Eastman Cloth Cutting and Cloth Spreading Machines

Website: www.EastmanCuts.com